

# **CIMO**

JEWELRY MACHINES & PRODUCTS

WWW.CIMOSRL.IT

## **VACUUM INVESTMENT MIXER ST. LOUIS MINIMIX**



## **INSTRUCTION MANUAL**

# INDEX

<b>CE CONFORMTY DECLARATION .....</b>	<b>3</b>
<b>INTRODUCTION.....</b>	<b>4</b>
<b>WARRANTY.....</b>	<b>4</b>
<b>GENERAL NOTES.....</b>	<b>4</b>
<b>MACHINE FEATURES .....</b>	<b>4</b>
<b>OPERATOR SAFETY.....</b>	<b>4</b>
<b>TRANSPORT .....</b>	<b>4</b>
<b>TECHNICAL DATA.....</b>	<b>5</b>
<b>VACUUM PUMP CONNECTION.....</b>	<b>5</b>
<b>PRELIMINARY OPERATION.....</b>	<b>5</b>
<b>WATER DOSING TANK AND GRADUATE STICKER SPECIFICATIONS.....</b>	<b>5</b>
<b>MIXER USE ( PART 1 ).....</b>	<b>6</b>
<b>CONTROL PANEL.....</b>	<b>6</b>
<b>PARAMETER SETTING.....</b>	<b>7</b>
<b>MIXER USE ( PART 2 ).....</b>	<b>8</b>
<b>UNIT DRAWING &amp; PARTS LIST.....</b>	<b>9 - 10</b>

# CIMO s.r.l.

Corso Novara 171/B - 27029 VIGEVANO (PV) ITALY  
TEL. (+39) 0381 82193 – FAX (+39) 0381 70251  
EMAIL: [cimob@tin.it](mailto:cimob@tin.it) - [www.cimosrl.it](http://www.cimosrl.it)



## CONFORMITY DECLARATION

### St. LOUIS MINIMIX

Machine: Vacuum investment mixer for jewellery casting process  
Model: ST. LOUIS MINIMIX

Serial n. 19 -  
Year made: 2019

CIMO s.r.l. is the producer of the above referred machine.

CIMO s.r.l. here declares to have designed and manufactured this unit for the INDUSTRIAL PURPOSE USE only.

CIMO s.r.l. declares that this machine complies with the requirements of :

“ CE DIRETTIVA MACCHINE “ 98/37/ EG

“ CE DIRETTIVA BASSA TENSIONE “ 72/23/ EWG modify to 93/68/EWG

“ CE DIRETTIVA COMPATIBILITA' ELETTRROMAGNETICA “ EMC 89/336

EWG 92 modify to 2004/108 EG

CEI 6 EN 60204 - 1.EN 292 - 1.EN 292 – 2.EN 294 e EN 61000-6-4 / EN 61000 - 6-2

The unit is conforming specifications “ ISO 7000 “ and it is marked CE.

Vigevano,

**C.I.M.O. srl - Gianluigi Barettoni**  
managing director

## **INTRODUCTION**

These notes are provided to our Customer in order to offer the informations necessary for the correct installation , operation use and maintenance of the unit purchased. Only technical staff, previously authorized by the Producer, will guarantee a correct service of the machine and its components.

Any modification or repair made without prior CIMO authorization and agreement, will immediately cancel warrenty conditions and this circumstance will save the producer from any kind of responsibility forward any person and things suffering damages that might occur. Please carefully read the instructions notes before operating the machine. CIMO is reserving the right to modify its products without previous notice.

## **WARRANTY**

**CIMO PRODUCTS ARE COVERED BY TWELVE MONTHS WARRANTY**

**STARTING FROM THE DELIVERY DATE TO CUSTOMER**

**EXCEPT ELECTRIC AND ELECTRONIC COMPONENTS THAT ARE COVERED SIX MONTHS ONLY.**

**WARRANTY IS LIMITED TO REPAIR OR CHANGE OF THE FAULT PARTS**

**UPON A PREVIOUS AUTHORIZATION AND INSPECTION BY OUR STAFF OR CIMO DELEGATE.**

**LABOUR, TRANSPORT, CUSTOMS AND OTHER COSTS WILL BE AT TOTAL CUSTOMER CHARGE.**

**THE TOTAL CHANGE OF THE COMPLETE MACHINE IS ALWAYS TO BE ESCLUDED FROM WARRANTY CONDITIONS. PARTS REPAIRED OR CHANGED WILL NOT EXTEND THE WARRANTY PERIOD.**

## **GENERAL NOTES**

St. Louis vacuum mixers are machines studied and designed for the investment mixing and flask mold filling for the lost wax casting of the jewelry making process. The main concept of the St.Louis mixing units is the total operativity under vacuum situation.

Traditionally investment was mixed with water in open air and with this process the final blend result was not really homogeneous and precise so the surface of the precious metal casted was not so smooth and complete.

More, the large quantity of gases incorporated in the mixing was giving such a huge percentage of porosity.

St.Louis mixer, with the vacuum total process and the timing, quantity and water dosing very precise, assures the best quality performing results in one of the most delicate process-step by step of the lost wax casting system.

## **THE MACHINE FEATURES**

- TOTAL INVESTMENT POWDER DEGASIFICATION INTO THE MIXING CONTAINER
- EXACT AND PRECISE WATER QUANTITY IN THE RATIO 1:40 TO BE ADDED TO POWDER
  - ADJUSTABLE MIXING SPEED
  - CORRECT AND PRESETTED MIXING TIMING
- ADJUSTABLE INTENSITY VIBRATION FOR THE INVESTED FLASKS

## **OPERATOR SAFETY**

***PROTECTION MASK FOR OPERATOR IS COMPULSORY REQUESTED***

***PROTECTION HAND GLOVES FOR OPERATOR ARE SUGGESTED***

***THIS UNIT MUST BE OPERATED BY PROFESSIONAL STAFF***

***AND FOR ITS CONCEPT PURPOSE BUILT ONLY !***

## **TRANSPORT**

THE MACHINE SHOULD BE ALWAYS TRANSPORTED IN VERTICAL POSITION AND HAS TO BE LIFTED FROM THE BOTTOM CHASSIS BASEMENT ONLY.

## **ATTENTION**

PLEASE AVOID TO HOLD, LIFT OR PULLING AND PUSHING THE MACHINE FROM ITS CENTRAL CONSTRUCTION PART ( PLEXIGLASS MIXING BOWL, FLASK CHAMBER OR MAIN MOTOR SHAFT)

## **TECHNICAL DATA**

VOLTAGE: 220 V. - 50/60 HZ. SINGLEPHASE – CONSUMPTION: KW. 0,8 PROTECTION FUSE: 4 AMP.  
MAX INVESTMENT CAPACITY : GRAMS 800 - MAX FLASK SIZE: DIAMETER 100 mm. X 120 mm. HIGHT

### **VACUUM PUMP CONNECTION**

THE MIXER MUST OPERATES WITH A VACUUM PUMP OF MINIMUM CAPACITY 6 CBM/HOUR.  
THE VACUUM PUMP IS SUPPLIED SEPARATELY AS OPTIONAL ACCESSORY.  
ON THE REAR PART OF THE MACHINE BASE FIND THE VACUUM PIPE HOSE CONNECTOR.  
VACUUM PUMP MUST BE CONNECTED DIRECTLY TO A SEPARATE 220 VOLTS PLUG.

### **PRELIMINARY OPERATIONS**

Connect the vacuum hose from the rear part of the machine to an external vacuum pump (6 cbm/h.).  
WHENEVER THE UNIT IS SUPPLIED WITH OUR VACUUM PUMP,  
REMINDE TO FILL THE PUMP OIL TANK WITH ITS SPECIFIC OIL  
BEFORE SWITCHING ON THE PUMP MOTOR.  
Connect the unit to an electrical plug that must have ground.  
Fill the open dosing tank ( located on the right part of the motor column of the unit )  
with clean water ( temperature between 20° and 24° C. ) correctly to the top level line  
of the sticker indicating the water proportion quantity. ( ratio: 1 kg. powder = 400 cc. water )

## WATER DOSING TANK AND STICKER SPECIFICATIONS:

The sticker on the dosing water tank is indicating kg. and pounds with numbers from 0 to 2 ( kg. )  
IT IS PRINTED CONSIDERING THE STANDARD RATIO: 1 KG. DRY INVESTMENT  
POWDER = 400 CC. WATER

THE STICKER LINES AND NUMBERS ARE INDICATING THE DRY POWDER GRAMS ( or  
POUNDS )

FROM TOP LINE WATER LEVEL ( under KG printed ) THE QUANTITY OF WATER  
CORRESPONDING TO EACH KILOGRAM IS 400 CC.

*Practical example:*

IF WE HAVE LOADED kg. ,700 INVESTMENT DRY POWDER INTO THE MIXING  
CONTAINER, WE HAVE TO TRANSFER INTO THE MIXING CONTAINER A QUANTITY  
OF WATER AS MUCH AS WE SEE MARKED ON THE LEVEL LINE VALUE KG 1,7 ON  
THE DOSING COLUMN STICKER IN ORDER TO HAVE THE EXACT 40% PROPORTION  
OF WATER

FOR THE INVESTMENT LOADED IN THE MIXING CONTAINER.

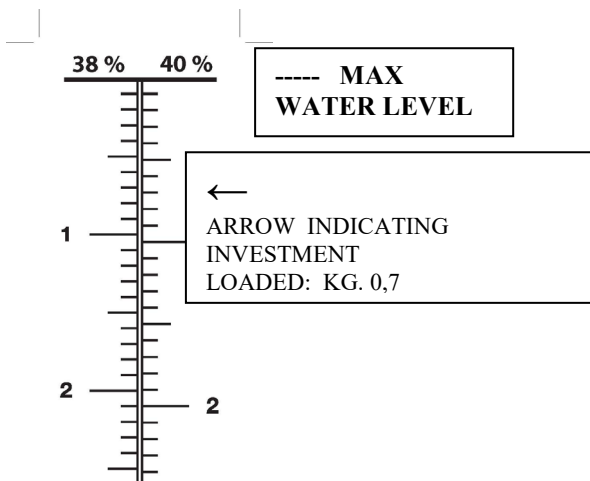

**Please be informed that the STICKER shows just 40% RATIO IN THE RIGHT SIDE and 38% RATIO IN THE LEFT SIDE**

**Attention: in presence of special Platinum Investment powder sometimes the requirement is to add a different water percentage. We supply with PT version sticker with 30 % ratio.**

**ATTENTION: in the water dosing tank is possible to put water and binder together, for PT investment that need. But is important when job is finish put only water inside the water dosing tank and using the vacuum transfer the water to mixing chamber to clean the water piping from the acid of the binder.**

## MIXER USE ( part one ):

Lift up the top motor ( 1 ) located on the unit column and turn it to the right side of the mixer.  
 DISCONNECT THE FAST JOINTER ( REF. 5 )  
 Remove the top black cover with the mixing blade from the clear mixing chamber ( 2 )

Place the flask (with wax tree on its rubber base) on the central part of the lower black plate base ( 3 ) of the MIXER.  
 Load the investment powder (after its weighting ) into the mixing chamber . Check that the pouring valve ( 4 ) of mixing chamber is logically closed .

### **BE SURE THAT THE MIXING CHAMBER IS DRY**

Replace the mixing chamber on its original location and insert the mixing blade on it. Place the top cover on it and connect pipe for tap ( ref 5 ). Be sure that vacuum release valve (6) is closed.  
**REPLACE THE TOP MOTOR ON ITS POSITION**  
 ( shaft into the blade-gear )

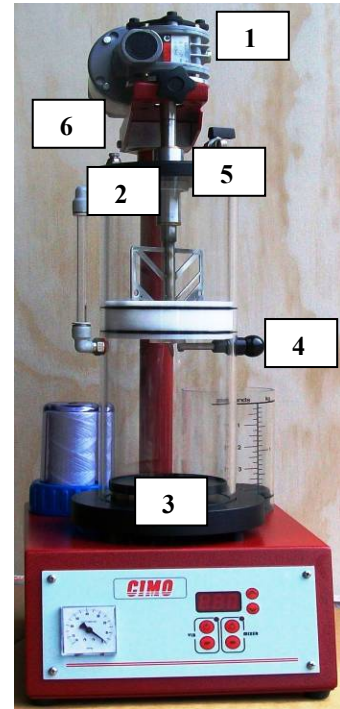

## FRONT CONTROL PANEL

- 1 vacuum gauge
- 2 increase value
- 3 decrease value

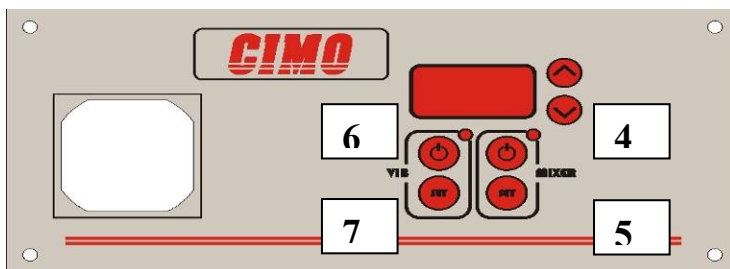

- 4 on – off mixing motor
- 5 motor speed
- 6 on – off vibrator
- 7 vibrator intensity

**VIB** vibration control  
**MIXER** mixing control

**A SELF AUTOMATIC SWITCH-OFF HAS BEEN INSTALLED IN THE MACHINE**  
 Whenever the unit will remain for more than one minute without operation it will switch off automatically

## **PARAMETER SETTING:**

### **WHEN SWITCHING ON THE MACHINE, THE DISPLAY SHOWS THE MIXING TIME PRESETTED:**

Example: 4.5 means 4 minutes and 30 seconds / 3.0 means 3 minutes zero seconds.

To modify the mixing time ( operation possible only when mixing motor is OFF )  
increase or decrease time by pushing “ 2 “ or “ 3 “ button.

The value is automatically memorized.

### **MIXING MOTOR SPEED:**

This value has been pre settled already by CIMO srl.

To set a different mixing motor speed ( operation possible when mixing motor is ON or OFF ):

- a) push button “5” until led is flashing
- b) increase or decrease motor speed by pushing “2” or “3”
- c) after 5 seconds from the last pushing on 2 or 3 the setting procedure is over.
- d) WHEN SWITCHING OFF THE MACHINE the parameter will go back again to the initial CIMO value.

### **VIBRATION INTENSITY:**

To set the vibration intensity ( operation possible when vibration is ON or OFF ):

- a) push button “7” until led is flashing
- b) increase or decrease vibration intensity by pushing “2” or “3”
- c) after 5 seconds from the last pushing on 2 or 3 the setting procedure is over.
- d) WHEN SWITCHING OFF THE MACHINE the parameter will go back again to the initial CIMO value.

LEAVE THE FLASK SOME MINUTES TO DRY ON THE FLASK PLATE  
MEANWHILE THE OPERATOR IS WASHING AND RINSING THE BLADE AND THE  
MIXING CONTAINER.  
DRY ALL BEFORE A NEW OPERATION.

## **ALARMS ON DISPLAY**

**A 1 : ELECTRICAL SHORT – CONTROL BOARD DAMAGED**

**A 2 : MIXING MOTOR OVERHEATING**

**A 3 : MIXING MOTOR MECHANICAL FAULT ( too much powder loaded )  
( internal blade bearing dirty )  
( mixture too much dry )**

**A 4 : LOW TENSION AT THE UNIT**

*To reset the alarms: switch off and switch on the unit*



## **MIXER USE ( second part )**

ONCE THE INVESTMENT POWDER HAS BEEN LOADED INTO THE TOP PART OF THE MIXING CHAMBER ( A ) AND ALL THE MACHINE COMPONENTS HAVE BEEN PLACED IN THEIR ORIGINAL POSITION,  
CHECK THE TIME SETTED ON THE DISPLAY  
( WE SUGGEST 4 MINUTES: 4.0 )

START THE VACUUM PUMP MOTOR ( SEPARATE SWITCH EXTERNAL FROM THE UNIT ) AND LEAVE THE VACUUM PUMP RUNNING UNTIL THE VACUUM LEVEL GAUGE IS REACHING THE VACUUM CONDITION.  
( MINIMUM VALUE OF “ 60 ” ) THEN, SWITCH OFF THE PUMP.

OPEN THE TOP WATER TAP ( B ) AND WATER WILL FLOW DIRECTLY INTO THE MIXING CHAMBER.  
CLOSE IMMEDIATELY THE TAP WHEN THE WATER LEVEL OF THE DOSING TANK WILL REACH THE CORRESPONDENT LINE OF THE INVESTMENT QUANTITY LOADED.  
( AS FOR INSTRUCTIONS ON PREVIOUS PAGE ).

START THE MIXING BY PUSHING BUTTON “4”  
WHEN THE MIXING TIME PRESETTED WILL BE ZERO, THE MOTOR OF THE MIXING BLADE WILL STOP AND A BUZZER WILL SOUND TO WARN THE OPERATOR FOR THE IMMEDIATE POURING OF THE MIXTURE INTO THE FLASK.

OPEN THE SIDE POURING VALVE KNOB ( E )  
( PULL TOWARD EXTERIOR ) IN ORDER TO FILL THE FLASK WITH THE MIXTURE.  
CLOSE THE VALVE ( E ) WHEN FLASK IS TOTALLY FILLED

START VIBRATION BY PUSHING BUTTON “ 6 ”  
AND KEEP THE VIBRATION INTENSITY SMOOTH FOR A COUPLE OF MINUTES.

STOP THE VIBRATION AND RELEASE VACUUM BY OPENING THE TOP ROUND SMALL VALVE OVER THE TOP COVER OF THE UNIT ( F )

PLEASE CONSIDER THAT ALL THE PROCESS IS DONE UNDER VACUUM SO DO NOT EXPECT TO SEE “BOILING-BUBBLING” FROM THE INVESTED FLASK. IN ORDER TO GET AN EXACT VIBRATION INTENSITY PLACE YOUR HAND ON TOP MIXER COVER TO PRACTICALLY FEEL THE VIBRATION INTENSITY.

AT THE END OF THE OPERATIONS PLEASE NOTE THAT IT IS BETTER TO LEAVE THE FLASK ON THE FLASK PLATE OF THE MIXER AND QUICKLY WASH AND RINSE PROPERLY THE MIXING CHAMBER ( CARE TO CLEAN THE INTERNAL PART OF THE POURING VALVE, THE BLADE SHAFT AND THE INTERNAL PART OF THE TOP COVER )

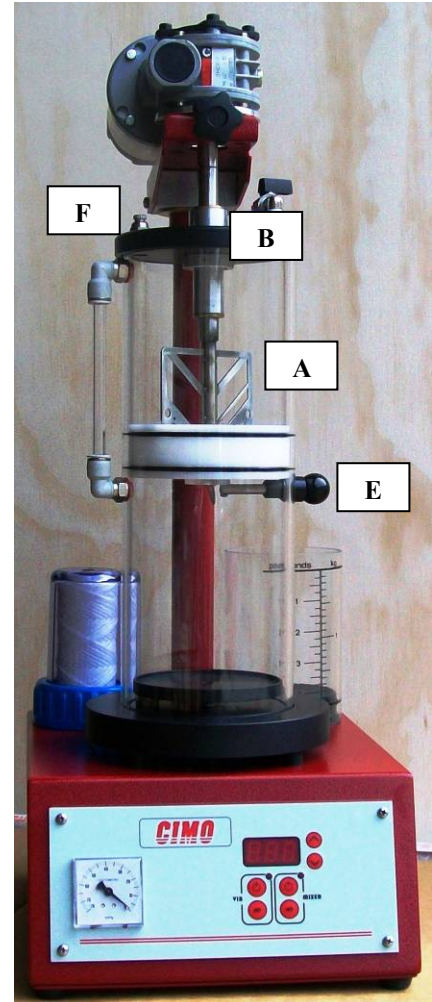

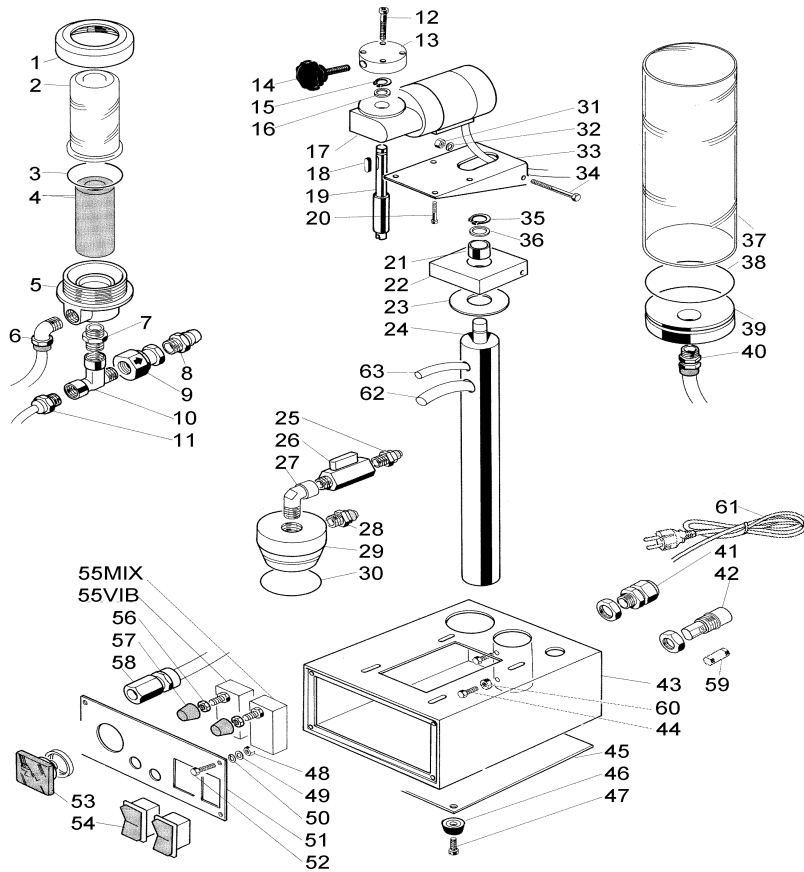

ELETTRONIC BOARD

N.	CODE	N.	CODE	N	
1	92LT2A	21	MIX92LT2A21	42	MIX92LT2A42
2	92LT2A	22	MIX92LT2A22	43	MIX92LT2A43
3	92LT2A	23	MIX92LT2A23	44	MIX92LT2A44
4	MIX92LT2A4	24	MIX92LT2A24	45	MIX92LT2A45
5	MIX92LT2A5	25	MIX92LT2A25	46	MIX92LT2A46
6	MIX92LT2A6	26	MIX92LT2A26	47	MIX92LT2A47
7	MIX92LT2A7	27	MIX92LT2A27	53	MIX92LT2A53
8	MIX92LT2A8	28	MIX92LT2A28	59	MIX92LT2A59
9	MIX92LT2A9	29	MIX92LT2A29	60	MIX92LT2A60
10	MIX92LT2A10	30	MIX92LT2A30	61	MIX92LT2A61
11	MIX92LT2A11	31	MIX92LT2A31	62	MIX92LT2A62
12	MIX92LT2A12	32	MIX92LT2A32	63	MIX92LT2A63
13	MIX92LT2A13	33	MIX92LT2A33		
14	MIX92LT2A14	34	MIX92LT2A34		
15	MIX92LT2A15	35	MIX92LT2A35		
16	MIX92LT2A16	36	MIX92LT2A36		
17	MIX92LT2A17	37	MIX92LT2A37		
17	MIX92LT2A17	38	MIX92LT2A38		
18	MIX92LT2A18	39	MIX92LT2A39		
19	MIX92LT2A19	40	MIX92LT2A40		
20	MIX92LT2A20	41	MIX92LT2A41		

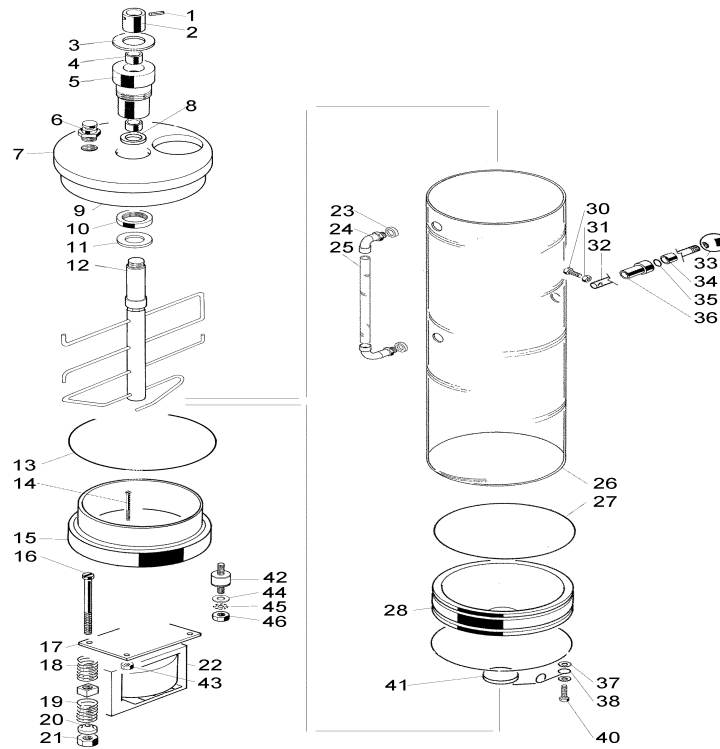

N.	CODE	N.	CODE
1	MIX92LT2B1	23	MIX92LT2B23
2	MIX92LT2B2	24	MIX92LT2B24
3	MIX92LT2B3	25	MIX92LT2B25
4	MIX92LT2B4	26	MIX92LT2B26
5	MIX92LT2B5	27	MIX92LT2B27
6	MIX92LT2B6	28	MIX92LT2B28
7	MIX92LT2B7	30	MIX92LT2B30
8	MIX92LT2B8	31	MIX92LT2B31
9	MIX92LT2B9	32	MIX92LT2B32
10	MIX92LT2B10	33	MIX92LT2B33
11	MIX92LT2B11	34	MIX92LT2B34
12	MIX92LT2B12	35	MIX92LT2B35
13	MIX92LT2B13	36	MIX92LT2B36
14	MIX92LT2B14	37	MIX92LT2B37
15	MIX92LT2B15	38	MIX92LT2B38
16	MIX92LT2B16	40	MIX92LT2B40
17	MIX92LT2B17	41	MIX92LT2B41
18	MIX92LT2B18	42	MIX92LT2B42
19	MIX92LT2B19	43	MIX92LT2B43
20	MIX92LT2B20	44	MIX92LT2B44
21	MIX92LT2B21	45	MIX92LT2B45
22	MIX92LT2B22	46	MIX92LT2B46